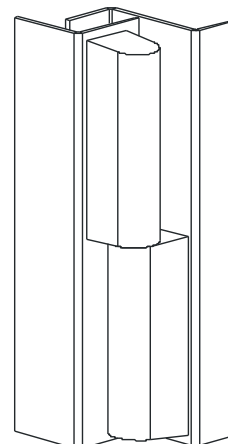
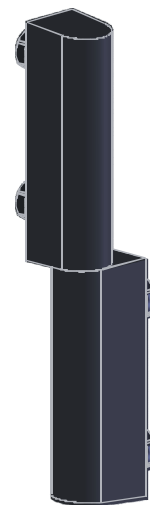
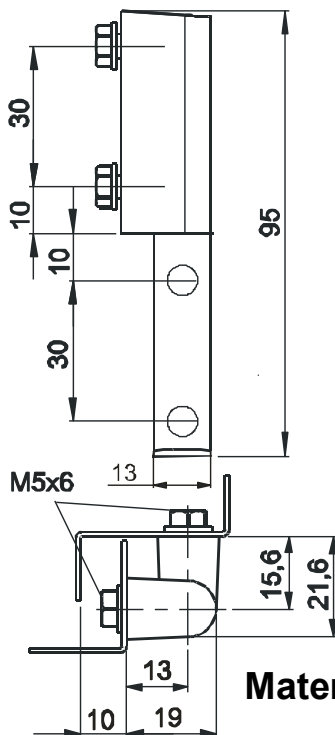
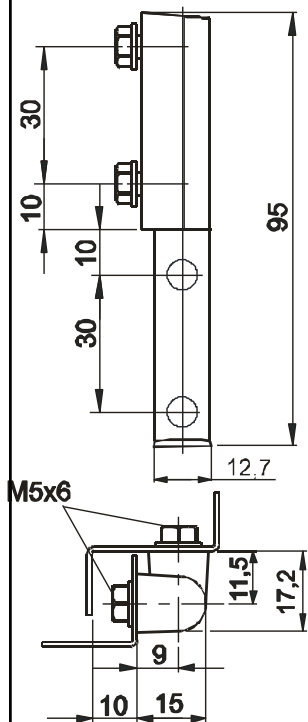
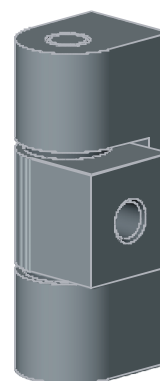
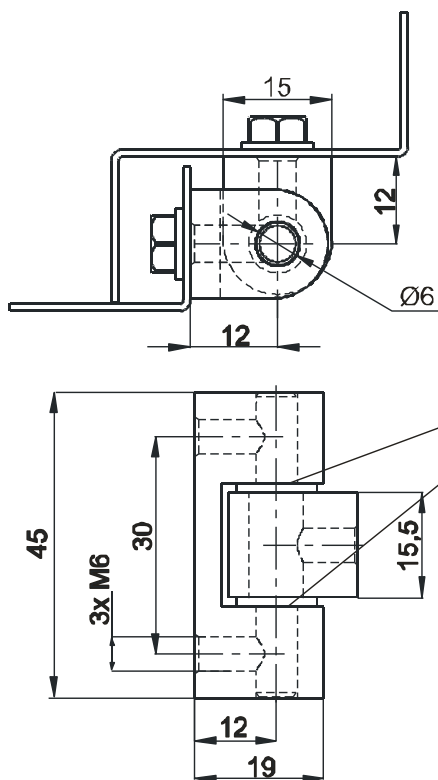

RT 59 Kat.č 03.627**RT 59-1** Kat.č 03.628

Materiál : Polyamid PA6 , RAL 9005
čep : ocel

Příklad objednávky : Závěs RT59 - 03.627

RT60 Kat.č 03.629

Materiál :

Tělo závěsu : -ocel, galvanic. chromováno **03.629**

-slitina ZnAl , galvanic. chromováno **03.630**

čep : ocel

Příklad objednávky závěsu: RT60, ocelový

Závěs RT60 03.629