

M1-PA

M2-PA

M3-PA

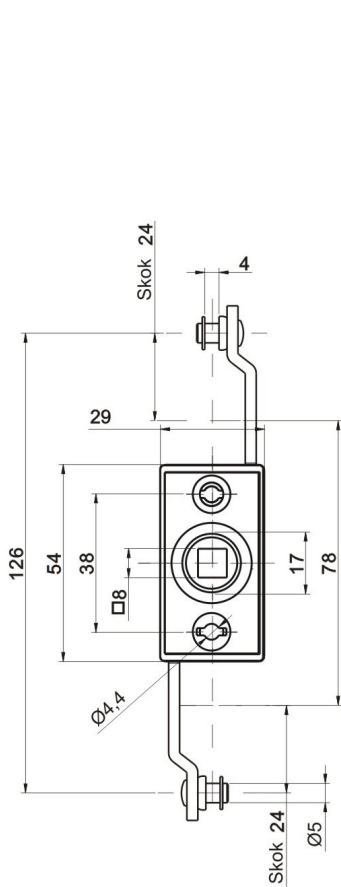

M1,2,3K - PA

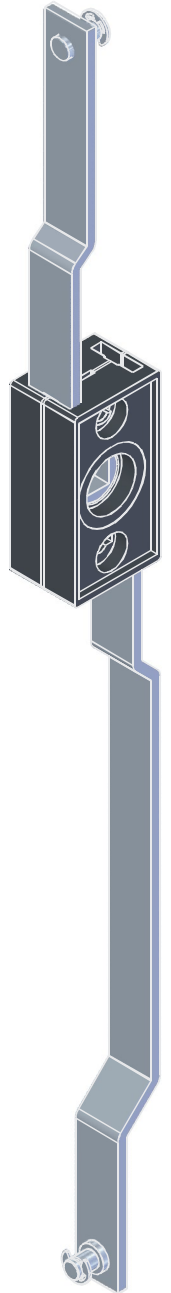
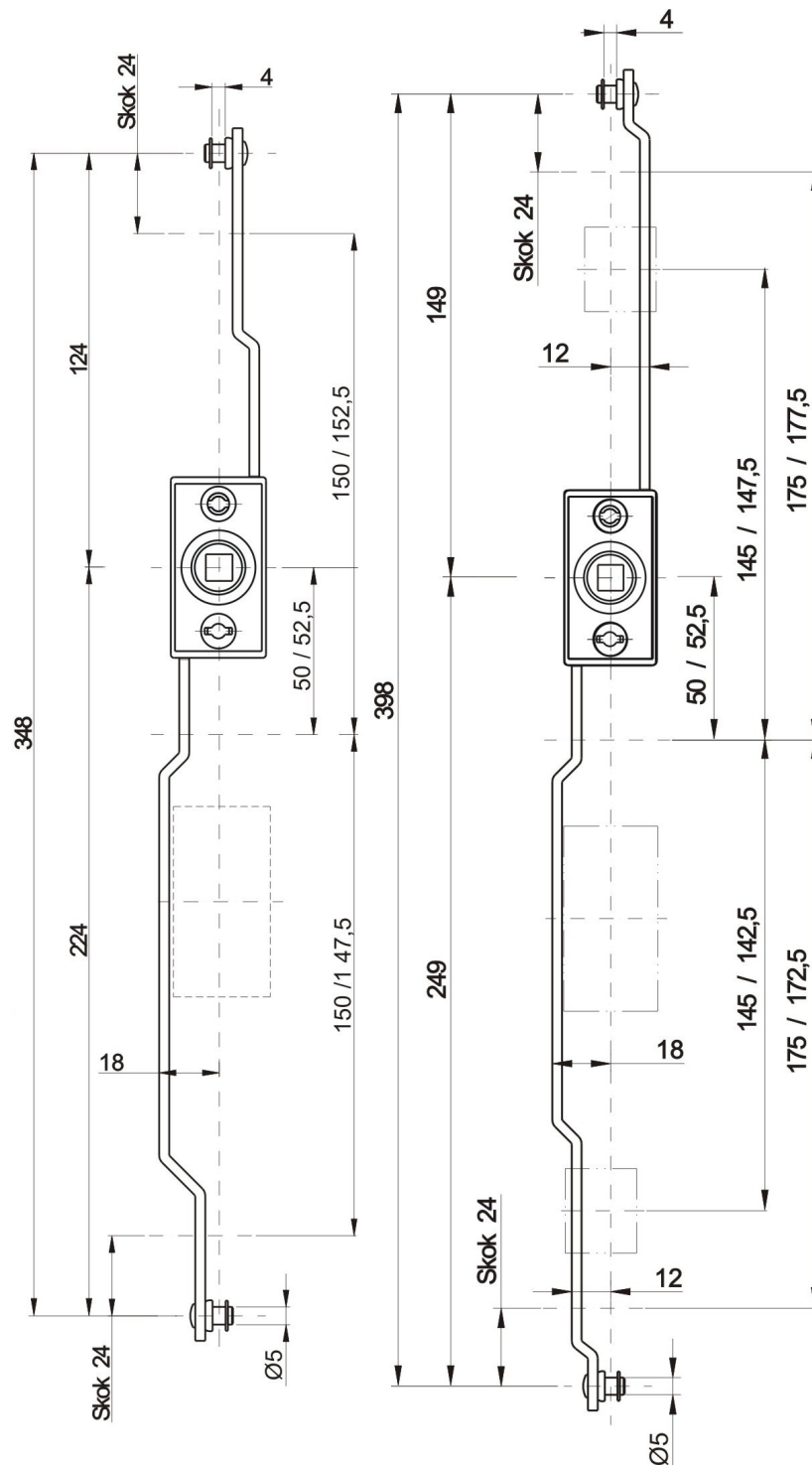
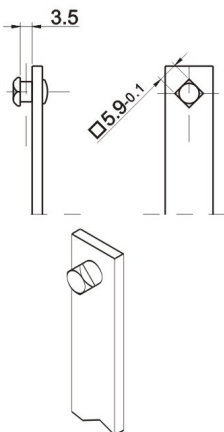

typ	kat.č.	typ	kat.č.
M1 - PA	03.670	M1K - PA	03.673
M2 - PA	03.671	M2K - PA	03.674
M3 - PA	03.672	M3K - PA	03.675

Materiál :

Tělo :polyamid

Táhla : ocel, zinkováno